

CLARKE[®]



WARNING: A suitable welding headshield must be worn during use
WARNING: Read these instructions before using the machine

MMA INVERTER WELDER

MODEL NO: MMA80

PART NO: 6012153

OPERATION & MAINTENANCE INSTRUCTIONS

UK
CA | CE



ORIGINAL INSTRUCTIONS

DL0422 ISSUE 2

INTRODUCTION

Thank you for purchasing this CLARKE Welder.

Before attempting to operate the machine, it is essential that you read this manual thoroughly and carefully follow all instructions given. In doing so you will ensure the safety of yourself and that of others around you, and you can also look forward to the product giving you long and satisfactory service.

Ensure the welder and its components suffered no damage during transit and that all components are present. Should any loss or damage be apparent, please contact your CLARKE dealer immediately.

GUARANTEE

This CLARKE product is guaranteed against faulty manufacture for a period of 12 months from the date of purchase. Please keep your receipt as proof of purchase.

This guarantee is invalid if the product is found to have been abused or tampered with in any way, or not used for the purpose for which it was intended.

Faulty goods should be returned to their place of purchase, no product can be returned to us without prior permission.

This guarantee does not effect your statutory rights.

TECHNICAL SPECIFICATIONS

Power Supply	230V/50Hz/1ph
Rated Max Input Current I_{1Max}/I_{1eff}	15.8A/7.1A
Ingress Protection	IP21S
Operating range	20-80 Amp
Range of welding electrodes	1.6-2.5 mm
Weight	3.77 kg (machine only)
Dimensions (L x W x H)	288 x 125 x 195 mm

SAFETY WARNINGS



WARNING: WHEN USING ELECTRICAL TOOLS, BASIC SAFETY PRECAUTIONS SHOULD ALWAYS BE FOLLOWED TO REDUCE THE RISK OF FIRE, ELECTRIC SHOCK AND PERSONAL INJURY

WARNING: READ ALL THESE INSTRUCTIONS BEFORE ATTEMPTING TO OPERATE THIS PRODUCT AND KEEP THESE INSTRUCTIONS IN A SAFE PLACE.

ELECTRIC SHOCK

1. Do not touch live electrical parts.
2. Never use electrode holders or cables which are damaged.
3. Keep the working environment, equipment, cables and clothing free from grease, oil, moisture and dirt.
4. Ensure the welding machine has been correctly earthed.
5. The operator must be insulated from the floor and work bench using a dry insulation mat.
6. Always ensure a second person is present in case of accident.
7. Keep welding cables away from power cables.
8. Regularly inspect the condition of the cables for signs of damage.
9. Remove the plug from the mains socket when not in use.
10. Ensure the earth connector is secured to bare metal adjacent to the weld, and when not in use insulated for safety. - Keep all equipment well maintained.

FUMES & GASES

1. The welding process generates hazardous fumes as a by-product. Inhalation of these fumes is hazardous to health.
2. Keep your face away from the weld to avoid breathing the fumes.
3. If welding in confined spaces ensure adequate ventilation and use a fume extractor.
4. By-products of welding can react to create a toxic/explosive environment.

FIRE OR EXPLOSION

1. Welding can cause fire and explosions. Precautions should be taken to prevent these hazards.

2. Before starting work ensure the area is clear of flammable materials and move any combustible materials to a safe distance, especially substances likely to generate a dangerous vapours.
3. The welding arc can cause serious burns. Avoid contact with skin.
4. Sparks and molten metal may be ejected during welding. Take precautions to prevent fire.
5. Sparks and molten metal can pass through gaps. Be aware that fire can start out of sight.
6. Do not weld to pressurised containers. or containers containing flammable vapours e.g. fuel tanks.
7. Always have appropriate fire fighting equipment to hand suitable for use in electrical environments.
8. Avoid carrying any fuels with you e.g. cigarette lighters or matches.

PERSONAL PROTECTION

1. The body should be protected by suitable clothing.
2. The use of neck protection may be necessary against reflected radiation.
3. Arc machines generate a magnetic field which is detrimental to pacemakers. Consult your doctor before going near active welding equipment/operations.
4. The UV and IR radiation generated by welding is highly damaging to the eyes, causing burns. This can also affect the skin.
5. Always use suitable welding shields equipped with appropriate filters.
6. Where there are pedestrians and traffic ensure a protective screen is used to avoid accidental arc glare.
7. Do not weld in the vicinity of children or animals and ensure no one is looking before striking an arc.
8. Wear hearing protection if required.
9. Allow the weld to cool. Hot metal should never be handled without gloves.
10. Take care when adjusting or maintaining the electrode/holder, that it has had time to cool sufficiently and the welder is disconnected from the mains supply.
11. First aid facilities and a qualified first aid person should be available unless medical facilities are close by, for immediate treatment of flash burns of the eyes and skin burns.
12. Flammable hair sprays/gels should not be used by persons welding.

PROTECTIVE CLOTHING







1. Wear gauntlet type gloves designed for use when welding.
2. Wear a fire resistant apron and protective shoes.
3. Wear cuffless trousers (not turned up) to avoid catching sparks and slag.
4. Avoid wearing oily or greasy clothing.
5. Wear protective head and shoulder coverings if welding overhead.
6. Wear a helmet with safety goggles or glasses with side shields underneath, appropriate filter lenses or plates (protected by clear glass). This is a MUST for welding (and chipping) to protect the eyes from radiant energy and spatter. Replace cover glass when broken, pitted, or spattered.

NOTE: All protective wear inc. masks & head shields MUST comply with Personal Protective Equipment Directive 89/686/EEC.

ADDITIONAL SAFETY PRECAUTIONS FOR WELDING

1. Always ensure that there is ample free air circulating around the outer casing of the machine, and that the louvres are unobstructed.
 2. Always inspect the cable before use to ensure it is in good condition.
 3. Always remove all flammable materials from the welding area.
 4. Always keep a fire extinguisher handy;-Dry Powder, CO² or BCF, NOT Water.
 5. Never remove the cover panels unless the machine is disconnected from the power supply, and never use the machine with the panels removed.
 6. Never attempt any electrical or mechanical repair unless you are a qualified technician. If you have a problem with the machine contact your local CLARKE dealer.
 7. Never use or store in a wet/damp environment.
 8. Never continue to weld, if, at any time, you feel even the smallest electric shock. Stop welding IMMEDIATELY and DO NOT attempt to use the machine until the fault is diagnosed and corrected.
 9. Never allow the earth cable or hose to become wrapped around the operator or any person in the vicinity.
 10. Never change electrodes with bare hands or damp gloves.
- Please read these instructions carefully and retain for future reference.

SAFETY SYMBOLS

	<p>Read this instruction booklet carefully before use.</p>		<p>Do not expose to rain.</p>
	<p>Wear eye protection</p>		<p>Recycle unwanted materials instead of disposing of them as waste. All tools, accessories and packaging should be sorted, taken to a recycling centre and disposed of in a manner which is compatible with the environment.</p>
	<p>Wear protective gloves</p>		
	<p>Wear a dust mask</p>		

ENVIRONMENTAL RECYCLING POLICY



Through purchase of this product, the customer is taking on the obligation to deal with the WEEE in accordance with the WEEE regulations in relation to the treatment, recycling & recovery and environmentally sound disposal of the WEEE.

In effect, this means that this product must not be disposed of with general household waste. It must be disposed of according to the laws governing Waste Electrical and Electronic Equipment (WEEE) at a recognised disposal facility.

If disposing of this product or any damaged components, do not dispose of with general waste. This product contains valuable raw materials. Metal products should be taken to your local civic amenity site for recycling of metal products.

ELECTRICAL CONNECTIONS



WARNING! READ THESE ELECTRICAL SAFETY INSTRUCTIONS THOROUGHLY BEFORE CONNECTING THE PRODUCT TO THE MAINS SUPPLY.

Connect the mains lead to a standard, 230 Volt (50Hz) electrical supply through an approved 13 amp BS1363 plug, or a suitably fused isolator switch.

If the plug has to be changed because it is not suitable for your socket or because of damage, it must be removed and a replacement fitted, following the wiring instructions shown below. The old plug must be discarded safely as insertion into a power socket could cause an electrical hazard.



WARNING: THE WIRES IN THE POWER CABLE OF THIS PRODUCT ARE COLOURED IN ACCORDANCE WITH THE FOLLOWING CODE:
BLUE = NEUTRAL BROWN = LIVE YELLOW AND GREEN = EARTH.

The wires in the mains lead should be wired up in accordance with the following colour code:

- Connect the GREEN & YELLOW coloured wire to the plug terminal marked with a letter E or .
- Connect the BROWN coloured wire to the plug terminal marked a letter "L".
- Connect the BLUE coloured wire to the plug terminal marked a letter "N".

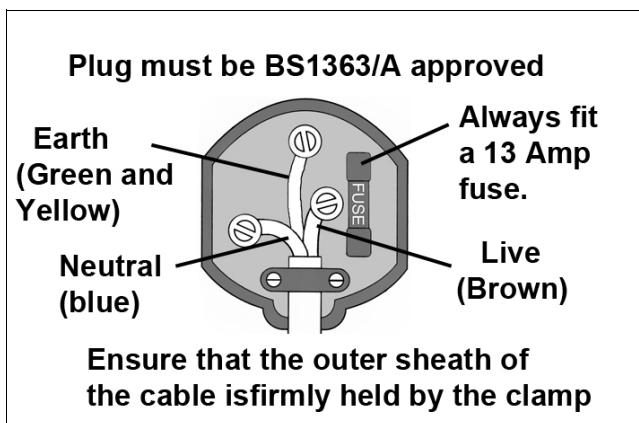

We strongly recommend that this machine is connected to the mains supply via a Residual Current Device (RCD). If you are not sure, consult a qualified electrician. DO NOT try to carry out any repairs yourself.

OVERVIEW



1	Power on LED (green)	7	Negative Terminal
2	High temperature LED (yellow)	8	Earth Cable
3	Welding current adjustment knob	9	Electrode holder
4	Power Switch (behind unit)	10	Carrying Strap
5	Welding current display	11	Welding Mask
6	Positive Terminal		

The following components are supplied with the MMA80 welding machine;

- Electrode holder with cable
- Face Mask (in two parts plus handle)
- Dark glass filter lens (Shade no 11) for mask
- Earth clamp with cable
- Clear protective glass lens for mask

MAIN FEATURES

ARC-FORCE	Automatically increases the current to prevent the electrode sticking when operating with a short arc length .
HOT START	Increases the welding current at the beginning of the welding process.
ANTI-STICK	The electrode can be easily withdrawn without it becoming damaged.

INVENTORY

The following components are supplied with the 80 Amp welding machine;

- Electrode holder with cable
- Earth clamp with cable
- 1 x Welding Shield Assembly with Clear & Dark glass filter lens (Shade no 11)

ASSEMBLING THE WELDING SHIELD

1. The welding shield shown on page 12 is supplied flat for shipping. Fold the sides of the shield around and clip to the top panel.
2. Insert both the glass lens panels into the recess inside the shield.
 - The clear glass must be fitted first to face the outside.
3. Insert the two plastic screws and use the plastic wingnuts to clamp the glass panels to the shield.
 - The clear glass panel should be replaced when it becomes badly pitted.



- When replacing the glass panels, only use parts supplied by Clarke International. The dark panel is a certified, optical glass and should not be exchanged for any other type.
- Secure the handle in position using the plastic nuts provided.

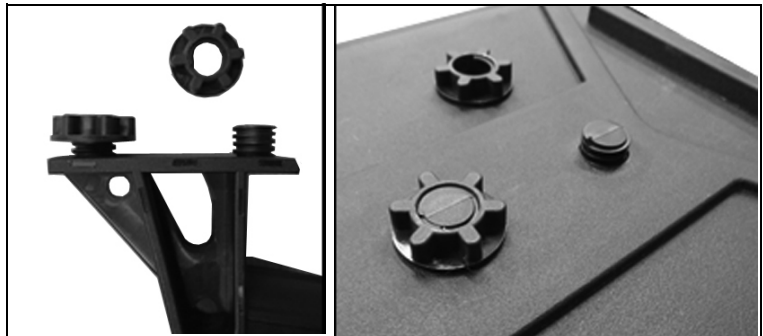

- The handle will be on the inside of the shield.

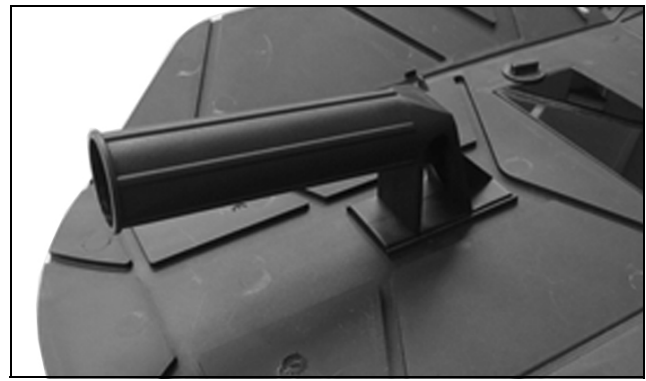

SETUP OF THE WELDER

CONNECTING THE CABLES

Make sure the on/off switch on the rear panel is in the OFF position before connecting the leads.

- Connect the earth (ground) cable to the negative terminal (-).

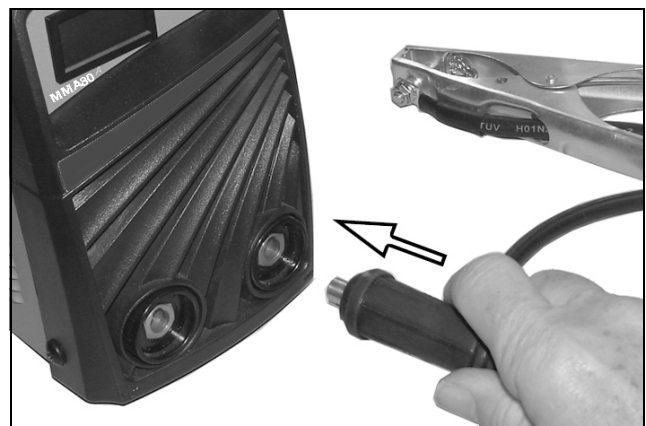

2. Connect the electrode holder cable to the positive terminal (+).

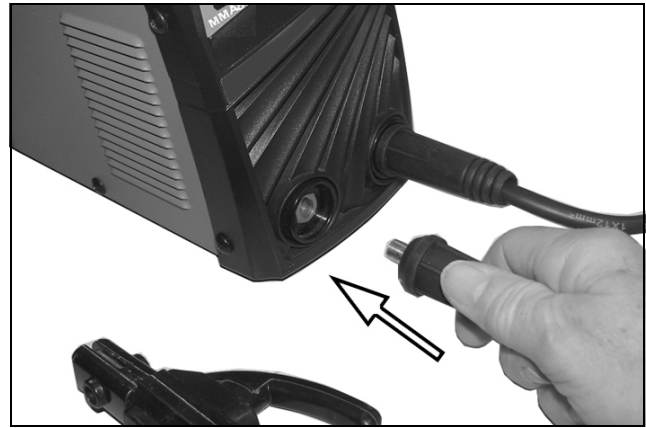

PREPARING THE WORKPIECE

The area being welded should be perfectly clean. Any coating, plating or corrosion must be removed, otherwise a good weld will be impossible to achieve.

FITTING THE WELDING ROD

1. Select the appropriate welding rod and grasp it in the welding rod holder.
 - It should be approximately the same thickness as the metal being welded. Refer to the table below.

DUTY CYCLE

This welder is covered by regulations BS-EN60974-1(2012) and BS-EN 60974-10 (2014), where the Duty Cycle is expressed as a percentage of time the machine may be used in a given period, for a specified welding current.

e.g. When welding at 80 Amps the machine may be used for 2 minutes (20%) in any 10 minute period, or the machine may be used continuously, (100%) when welding at 36 Amps or less.

USING THE WELDER

1. Plug the welder in to the mains supply and switch on with the switch at the rear.
 - The green "power on" LED will illuminate.
2. Attach the earth clamp firmly to the workpiece as close as possible to the point of weld.
 - Ensure that the earth clamp is attached to clean, solid metal. If necessary thoroughly clean with a wire brush to guarantee a good connection.

SETTING THE WELDING CURRENT

1. Select the welding current by turning the adjustment knob and observing the setting on the digital display.
- The table below is an indicator of the welding rod used for a given thickness of material.

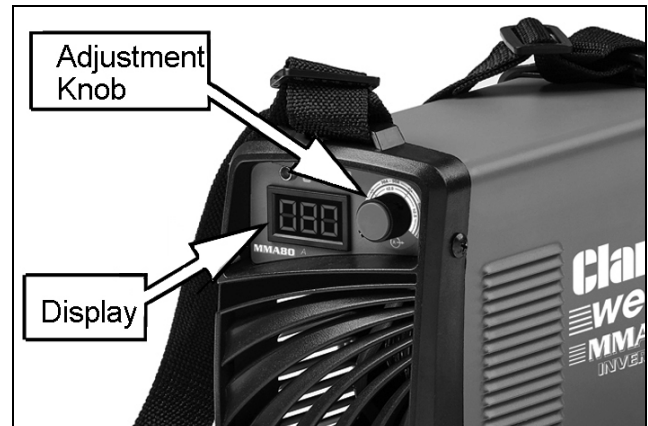

This is intended as a guide only.

SIZE OF WELDING ROD / THICKNESS OF METAL		Display reading
1.6 mm	1.0 - 2.0 mm	20 - 30 A
2 mm	1.5 - 2.5 mm	30 - 50A
2.5 mm	1.0 - 3.0 mm	50 - 80A

2. With practice you will get a feel for the best current settings for different welding rod thicknesses.

STRIKING AN ARC

IMPORTANT: BEFORE YOU STRIKE AN ARC, ALWAYS BRING THE FACE SHIELD UP TO PROTECT YOUR EYES.

1. Line up the electrode exactly over the spot where you want to strike the arc.
2. Position your shield in front of your face and tap down firmly with the electrode. Once you tap down and contact is made, you must instantly raise the electrode to the required arc gap.
 - The arc gap should be roughly the same as the diameter of the electrode.
 - If you withdraw the electrode too far once the arc is struck you will lose the arc and have to try again.

NOTE: One thing that usually happens when you are striking an arc is that the electrode sticks to the work. It should come unstuck with a sharp tug. If it will not free easily, then turn off the welder immediately as it will quickly start to overheat, then give the join a tap from a chipping hammer. As you get more experienced this will happen less.

3. Once the arc is struck, move the electrode along its intended path, keeping the tip in the molten pool at all times.

- You must also get used to feeding down the electrode steadily as it burns away.
 - An even crackling noise should be heard, which is an indication of a good weld.
4. Inspect the job carefully, the area of weld should be a complete fusion of the electrode and parent metal (s).
 - Any slag which forms on the surface should be chipped away with a suitable hammer/brush.
 - If the resultant weld looks messy and irregular, this is an indication of porosity or slag contamination and you have almost certainly failed to achieve the correct combination of working speed and current. This is a common problem, so do not worry as practice will quickly cure this.
 5. The electrode will need to be replaced when only 2-3 cm remains clear of the holder. Take care of the hot used electrode.
 6. If the machine stops after a period of work and the yellow LED comes on, the thermal overload device has intervened. Wait until the machine has cooled down and the light should go out. You can now continue welding.

WELDING PITFALLS

The arc welding technique is an acquired skill and requires considerable practice before perfect results are obtained. The diagrams below will help to explain the pitfalls in your technique and how to overcome them.

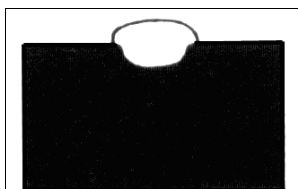

ARC TOO SHORT

This causes irregular masses of weld to be deposited, with slag contamination on an uneven surface.

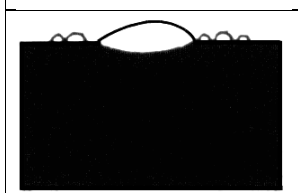

ARC TOO LONG

This causes poor penetration resulting in a weak weld with excessive spatter and porosity. The surface of the weld is rough and the arc makes a hissing sound.

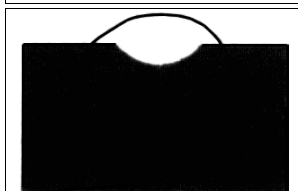

ELECTRODE MOVED TOO SLOWLY

This causes a very wide and heavy deposit which overlaps at the sides. It is wasteful both in terms of time and electrode use.

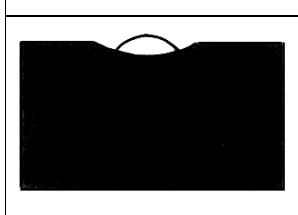

ELECTRODE MOVED TOO QUICKLY

This causes poor penetration with a 'stringy' and incomplete weld deposit. Slag is very hard to remove.

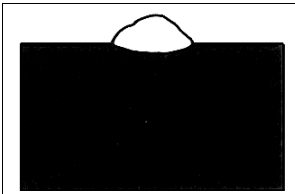

CURRENT TOO LOW

This causes poor penetration and causes the electrode to easily stick to the workpiece. It also results in a very irregular and high weld deposit. Slag is very hard to remove.

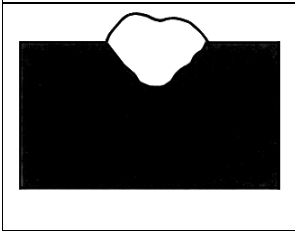

CURRENT TOO HIGH

This causes excessive penetration with spatter and a deep pointed crater. It may also cause holes to be burned in the workpiece.

This burns electrodes very quickly.

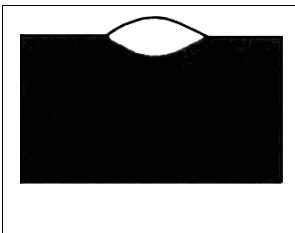

THE PERFECT WELD

With the correct combination of arc length, current regulation, inclination and speed of the electrode, you will, with practice produce the perfect weld.

This should be regular with uniform ripples and no slag contamination. The arc will make a steady crackling sound.

MAINTENANCE



WARNING: ELECTRICITY CAN KILL - NEVER TOUCH LIVE ELECTRICAL COMPONENTS.

WARNING: DISCONNECT THE POWER SUPPLY BEFORE ALL INSPECTION AND MAINTENANCE OPERATION BEWARE HOT SURFACES.

WARNING: ALWAYS LET THE POWER SUPPLY COOL DOWN BEFORE ACCESSING INTERNAL COMPONENTS.

The welder should be kept clear of any accumulation of dust which could block the air ventilation louvres and prevent proper cooling. If working in a dusty atmosphere, brush any dust downwards or use compressed air to remove dust.

Always inspect both cables before use to ensure they are in perfect condition and that the earth clamp is clean and secured correctly to the cable.

Consult your CLARKE dealer for any internal repairs if necessary.

STORAGE

1. Turn off the welder and disconnect it from the power supply.
2. Remove and coil the earth cable and electrode /cables and store them carefully.

Cover the unit and store in a dry location.

RATING PLATE

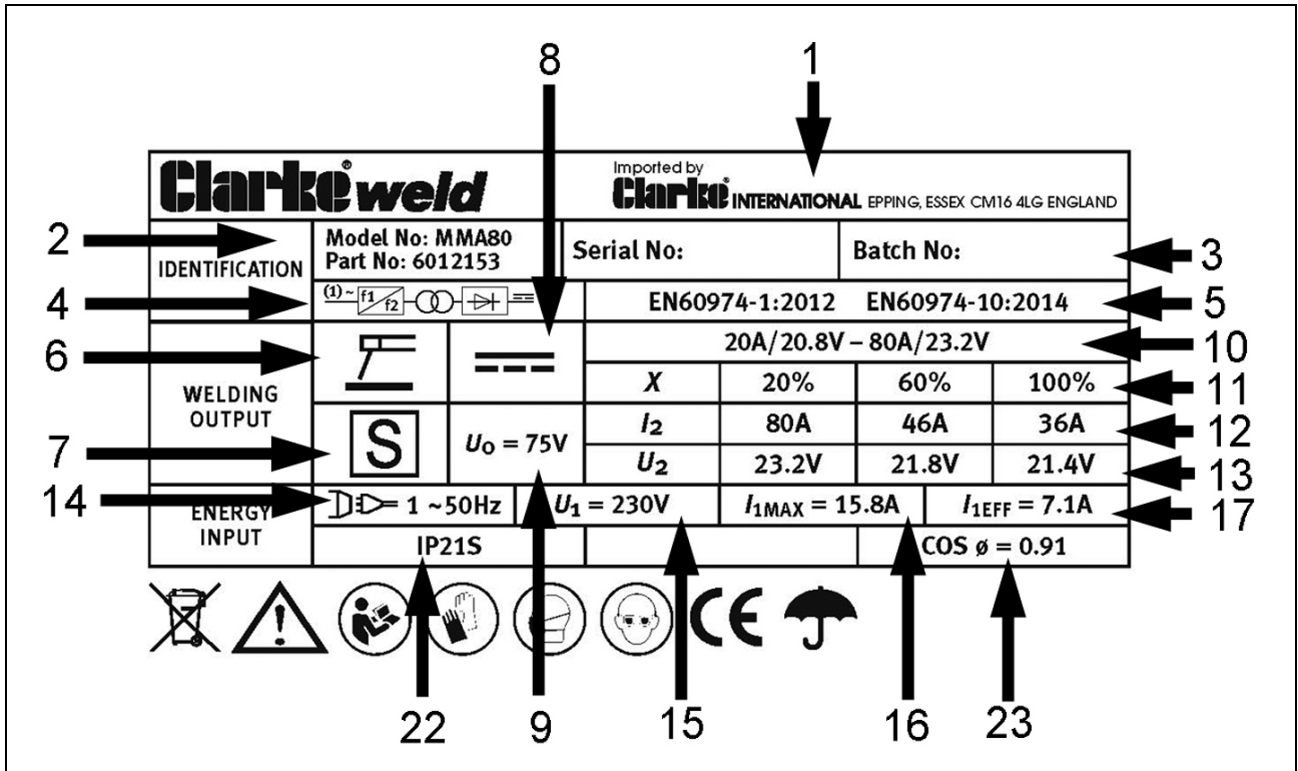

1	Name/address of manufacturer	13	Conventional Load Voltage
2	Model number/ part number	14	Energy Input symbol
3	Batch number	15	Rated supply voltage
4	Single phase transformer	16	Rated maximum supply current
5	British Standards applied	17	Maximum effective supply current
6	Manual metal arc welding with covered electrode	18	N/A
7	This symbol indicates that the unit is suitable for carrying out welding operations in an environment which has an increased risk of electric shock.	19	N/A
8	Welding Current symbol	20	N/A
9	Rated no-load voltage	21	N/A
10	Max welding current and corresponding load voltages	22	Degree of protection
11	Duty Cycle Percentage	23	Class of protection
12	Rated Welding current		

TROUBLESHOOTING

DEFECT	CAUSES	SUGGESTIONS
Unable to strike an arc	Bad clamp connection. Inverter printed circuit board is defective.	Check clamp connection. Contact your nearest CLARKE dealer.
No output voltage	Overheated machine (the yellow LED should be on).	Wait for thermal cutout to reset.
	Internal relay has failed.	Contact your nearest CLARKE dealer.
	Inverter printed circuit is defective.	Contact your nearest CLARKE dealer.
Wrong output current	Current selector control is defective.	Contact your nearest CLARKE dealer.
	Low power supply voltage.	Check the mains distribution system.
Porosity of welds	Acid electrode on steel with high sulphur content. Electrode oscillates too much. Workpieces are too far apart. Workpiece being welded is cold.	Use basic electrode. Move edges to be welded closer together. Move slowly at the beginning.
Cracks in weld	Material being welded is dirty (e.g. oil, paint, rust, oxides). Not enough current.	Cleaning the workpiece before welding is an essential method of achieving neat weld beads.
Poor penetration	Low current, high welding rate, reversed polarity. Electrode inclined in position opposite to it's movement.	Ensure operating variables are correct and improve preparation of work pieces.
Profile defects	Welding parameters are incorrect. Pass rate is incorrect operating parameter requirements. Electrode not inclined constantly while welding.	Follow basic and general welding principles.

DEFECT	CAUSES	SUGGESTIONS
Arc is unstable	Insufficient current.	Check condition of electrode and earth wire connection.
Electrode melts obliquely	Electrode core is not centred. Magnetic blow phenomenon.	Replace electrode. Connect two earth wires to opposite sites of the work piece.
Machine stops working.	Poor ventilation or high environmental temperature has caused the overheating protection to operate.	Improve ventilation.

ACCESSORIES

The following are some of the accessories available from your CLARKE dealer. Please quote the part numbers shown below:

DESCRIPTION	PART NUMBER
1.6 mm Welding Electrodes	3050580
2 mm Welding Electrodes	3050582
2.5 mm Welding Electrodes	3050586

A selection of

- welding headshields
- replacement lenses.
- welding clamps,
- welding screens,
- gauntlets,
- aprons

are also available from your Clarke dealer.

PARTS LIST/DIAGRAM

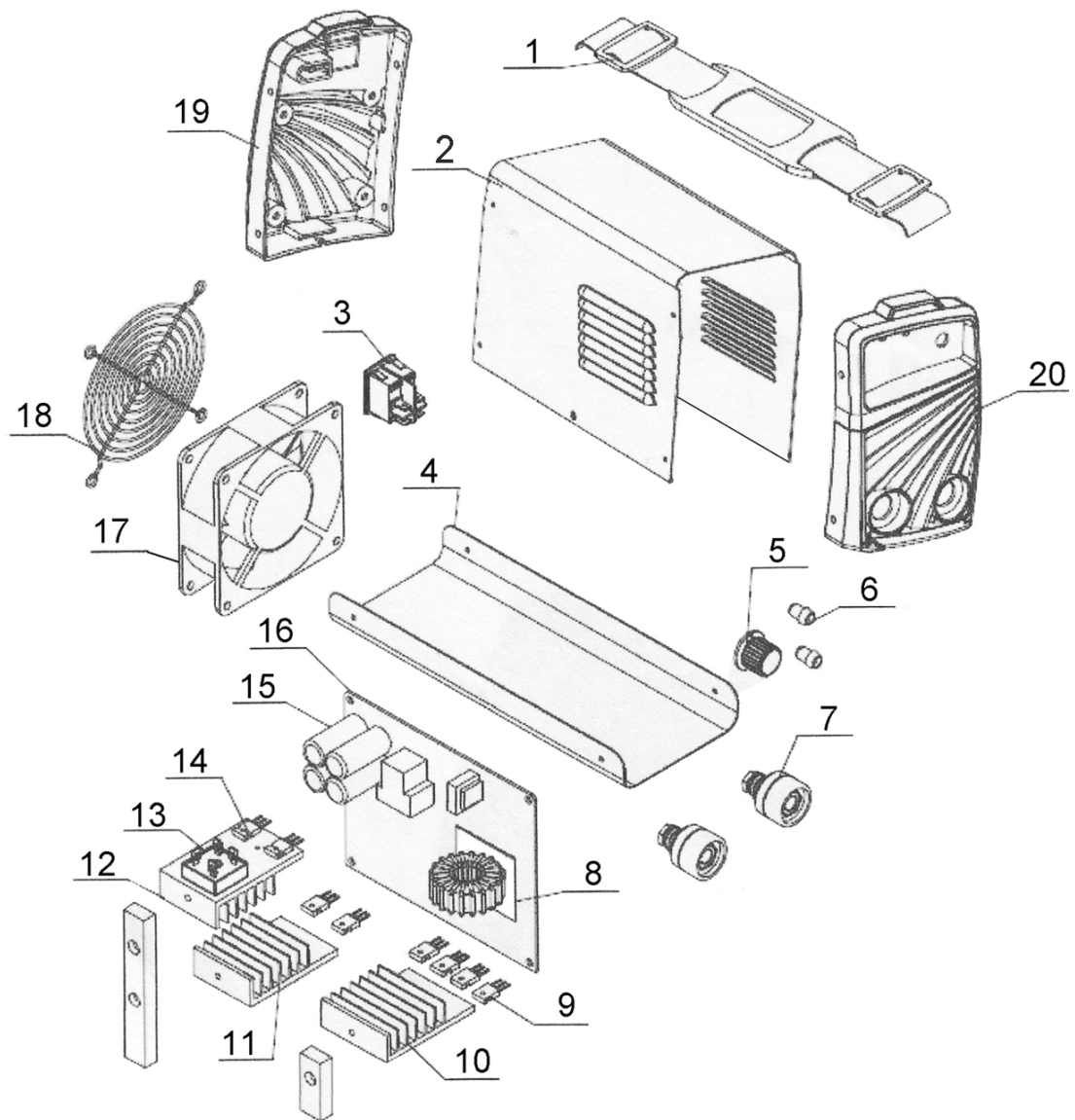

NO	DESCRIPTION	NO	DESCRIPTION
1	CARRY STRAP	11	COOLING FINS 2
2	MACHINE COVER	12	COOLING FINS 3
3	POWER SWITCH	13	RECTIFIER
4	BOTTOM PANEL	14	IGB TRANSISTOR
5	WELDING CURRENT KNOB	15	ELECTROLITIC CAPACITOR
6	LED INDICATOR	16	PRINTED CIRCUIT BOARD
7	DIN CONNECTOR	17	FAN
8	MAIN TRANSFORMER	18	FAN COVER
9	FAST RECOVERY DIODE	19	BACK PANEL
10	COOLING FINS 1	20	FRONT PANEL

DECLARATION OF CONFORMITY



Hemmill Street, Eppinge, Essex CM16 4LG

DECLARATION OF CONFORMITY

This is an important document and should be retained.

We hereby declare that this product(s) complies with the following statutory requirement(s):

Electromagnetic Compatibility Regulations 2016

Electrical Equipment (Safety) Regulations 2008

The Restriction of the Use of Certain Hazardous Substances in Electrical and Electronic Equipment Regulations 2012

The following standards have been applied to the product(s):

EN 60974-1:2014+A1:2015, IEC 61000-3-11:2000, IEC 61000-3-12:2011, EN 60974-1:2012,

EN 62321-1:2013, EN 62321-2:2014, EN 62321-3-1:2014, EN 62321-5:2014, EN 62321-6:2015,

EN 62321-7-1:2015.

The technical documentation required to demonstrate that the product(s) meet(s) the requirement(s) of the aforementioned legislation has been compiled and is available for inspection by the relevant enforcement authorities.

The UKCA mark was first applied in: 2022

Product Description: 80A MMA Inverter Welder

Model number(s): MMA80

Serial / batch Number: N/A

Date of issue: 26/04/2022

Signed:

J.A. Clarke
Director



Fitzwilliam Hall, Fitzwilliam Place, Dublin 2

DECLARATION OF CONFORMITY

This is an important document and should be retained.

We hereby declare that this product(s) complies with the following directive(s):

2014/30/EU

Electromagnetic Compatibility Directive

2014/35/EU

Low Voltage Equipment Directive

2011/65/EU

Restriction of the Use of Certain Hazardous Substances in Electrical and Electronic Equipment Directive

The following standards have been applied to the product(s):

EN 60974-1:2014+A1:2015, IEC 61000-3-11:2000, IEC 61000-3-12:2011, EN 60974-1:2012,

EN 62321-1:2013, EN 62321-2:2014, EN 62321-3-1:2014, EN 62321-5:2014, EN 62321-6:2015,

EN 62321-7-1:2015.

The technical documentation required to demonstrate that the product(s) meet(s) the requirement(s) of the aforementioned directive(s) has been compiled and is available for inspection by the relevant enforcement authorities.

The CE mark was first applied in: 2018

Product Description: 80A MMA Inverter Welder

Model number(s): MMA80

Serial / batch Number: N/A

Date of issue: 26/04/2022

Signed:

J.A. Clarke
Director

A SELECTION FROM THE VAST RANGE OF

Clarke®

QUALITY PRODUCTS



AIR COMPRESSORS
From DIY to industrial, Plus air tools, spray guns and accessories.

GENERATORS
Prime duty or emergency standby for business, home and leisure.

POWER WASHERS
Hot and cold, electric and engine driven - we have what you need

WELDERS
Mig, Arc, Tig and Spot.
From DIY to auto/industrial.

METALWORKING
Drills, grinders and saws for DIY and professional use.

WOODWORKING
Saws, sanders, lathes, mortisers and dust extraction.

HYDRAULICS
Cranes, body repair kits, transmission jacks for all types of workshop use.

WATER PUMPS
Submersible, electric and engine driven for DIY, agriculture and industry.

POWERTOOLS
Angle grinders, cordless drill sets, saws and sanders.

STARTERS/CHARGERS
All sizes for car and commercial use.



PARTS & SERVICE: 0208 988 7400

Parts Enquiries
Parts@clarkeinternational.com

Servicing & Technical Enquiries
Service@clarkeinternational.com

SALES: UK 01992 565333 or Export 00 44 (0)1992 565335

Clarke INTERNATIONAL Hemnall Street, Epping, Essex CM16 4LG
www.clarkeinternational.com